

Serie SGZ 10 / Series SGZ 10

● **MF.4010**

● **MF.4010MS**

mit Sensor
 with sensor



Druckluft
 max. 6 bar
 Arbeitsbereich:
 +5°C bis +70°C
 Haltekraft
 an der Greifer-
 spitze = 15 N
 Gewicht = 14 g
 mit Sensor = 22 g

Compressed air
 max. 6 bars

Working range:
 +5°C to +70°C

Holding force
 at jaw tip: 15 N

Weight = 14 g
 with sensor = 22 g

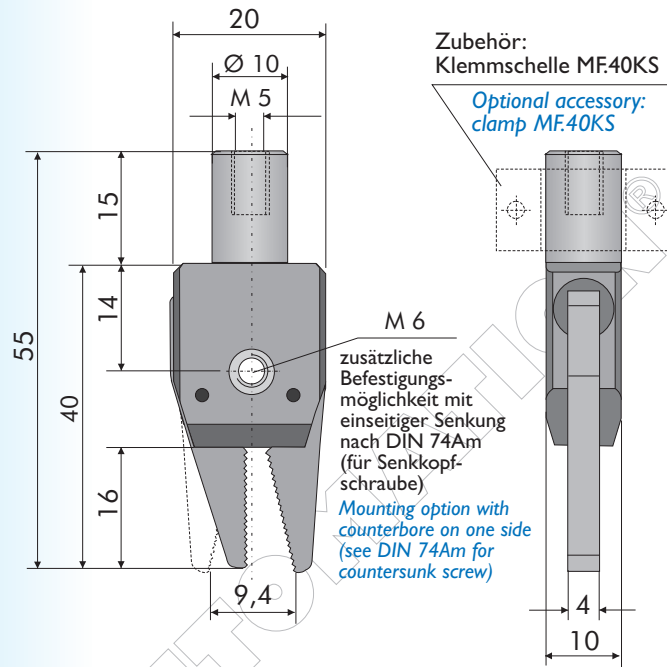

Ersatzteilkit:

Pos.	Bezeichnung	Art. Nr.
1	2 Greiferbacken	MF.40GB
2	1 Magnetbacke	MF.40MB
3	1 Sensorbacke mit Kabel	MF.40SB

Pos.	Bezeichnung	Art. Nr.
4	1 Druckfeder	MF.40DF
5	2 Kolben mit Dichtungen	MF.40KD
6	2 Passtifte	MF.40PS

Spare-parts kit:

Item	Designation	Art. No.
1	2 Gripper jaws	MF.40GB
2	1 Magnetic jaw	MF.40MB
3	1 Sensor jaw with cable	MF.40SB

Item	Designation	Art. No.
4	1 Compression spring	MF.40DF
5	2 Pistons with gaskets	MF.40KD
6	2 Dowel pins	MF.40PS

Für alle Greifzangen der Serie SGZ 10 / For all Series SGZ 10 grippers

